



Stainless Steel Crusher

10 Management Systems

——Zhengzhou Lerford Machinery Equipment Co.,ltd.



PART 01

Product Introduction





Type:



**Stainless Steel Crusher-Motor
Type**



**Stainless Steel Crusher-Water
Cooling System**



**Stainless Steel Grinder-Diesel
Engine Type**



Size:



Model	WSB-200	WSB-300	WSB-400	WSB-500	WSB-600	WSB-800
Capacity(kg/h)	10-50	30~200	50~300	70~400	100~500	500~1500
Speed of principal axis(r/min)	4200	4200	4200	4200	4200	4200
Size of input granules(mm)	< 15	< 15	< 15	< 15	< 15	< 15
Fineness of products (mesh)	12-120	12-120	12-120	12-120	12-120	12-120
Size	700*420*950	900*480*1100	930*600*1250	930*750*1360	1350*700*1120	1500*760*1350
Power(kw)	2.2	4	7.5	11	15	18.5/22
Weight	100	160	200	260	350	550
Price	\$1350	\$1800	\$2000	\$2850	\$3170	\$4100





Wide range of Applications:

Applicable scope



Oily material

Peanuts, walnuts, sesame, etc



Rice

Rice, barley, etc



Dry material

Soybeans, mung beans, etc



Flavoring

Chili peppers, Sichuanpeppers, etc



Hard material

Panax notoginseng, resin, etc



Food material

Danggui, Tianqi, etc

1. Oily materials

Applicable materials: peanuts, walnuts, sesame, almonds and other nuts.

2. Cereals

Applicable materials: rice, barley, oats, brown rice, etc.

3. Condiments and spices

Applicable materials: chili, pepper, star anise, cinnamon, poria, pearl powder, etc.

4. Food additives

Applicable materials: monosodium glutamate (MSG), salt, sugar, food-grade powder additives

5. Medicinal and edible raw materials

Applicable materials: Chinese medicinal materials such as angelica and Panax notoginseng.



Machine Advantages:



- 1 304 stainless steel inner material, safe and hygienic.
- 2 Can be equipped with circulating water cooling and dust removal device.
- 3 Removable structure, simple operation and easy to clean.
- 4 The grinding fineness can be adjusted by the screen.
- 5 Multifunctional, meeting the raw material processing needs of different industries.

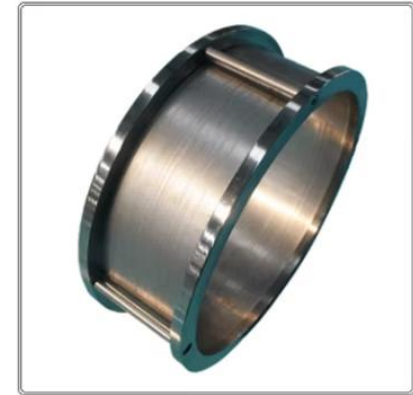

SCREEN

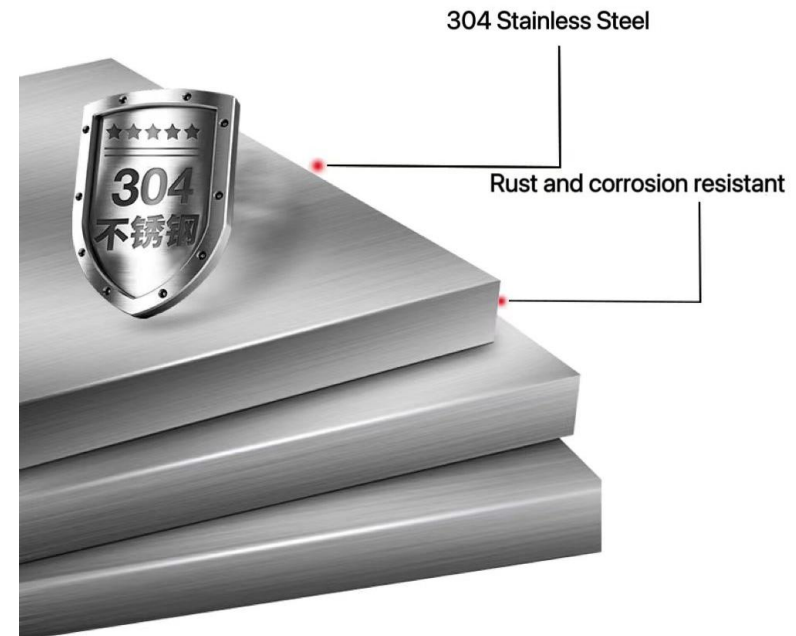



• Machine Structure:



1. Feeding Hopper: It is used to receive and temporarily store the raw materials to be processed, ensuring that the materials enter the crushing chamber evenly and continuously.
2. Air Supply Hole: Introducing external air to adjust the airflow in the crushing chamber or assist in material transportation.
3. Lock: Fix the moving parts of the machine to ensure stability and safety during operation.
4. Crushing Chamber: The material is broken up in this area by means of blades, hammers or squeezing action.
5. Discharge port: The crushed product is discharged from here and may be connected to a screen to control the particle size of the discharge.





The Spare part of the machine:

Part 1: Cold water pipe

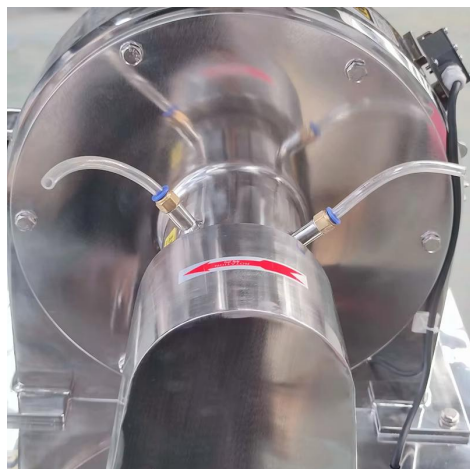

Part 2: Lock



Part 3: Feeding port



Part 4: Screen



Part 5: Discharge port



Part 6: Ventilation openings





• Machine drawings:

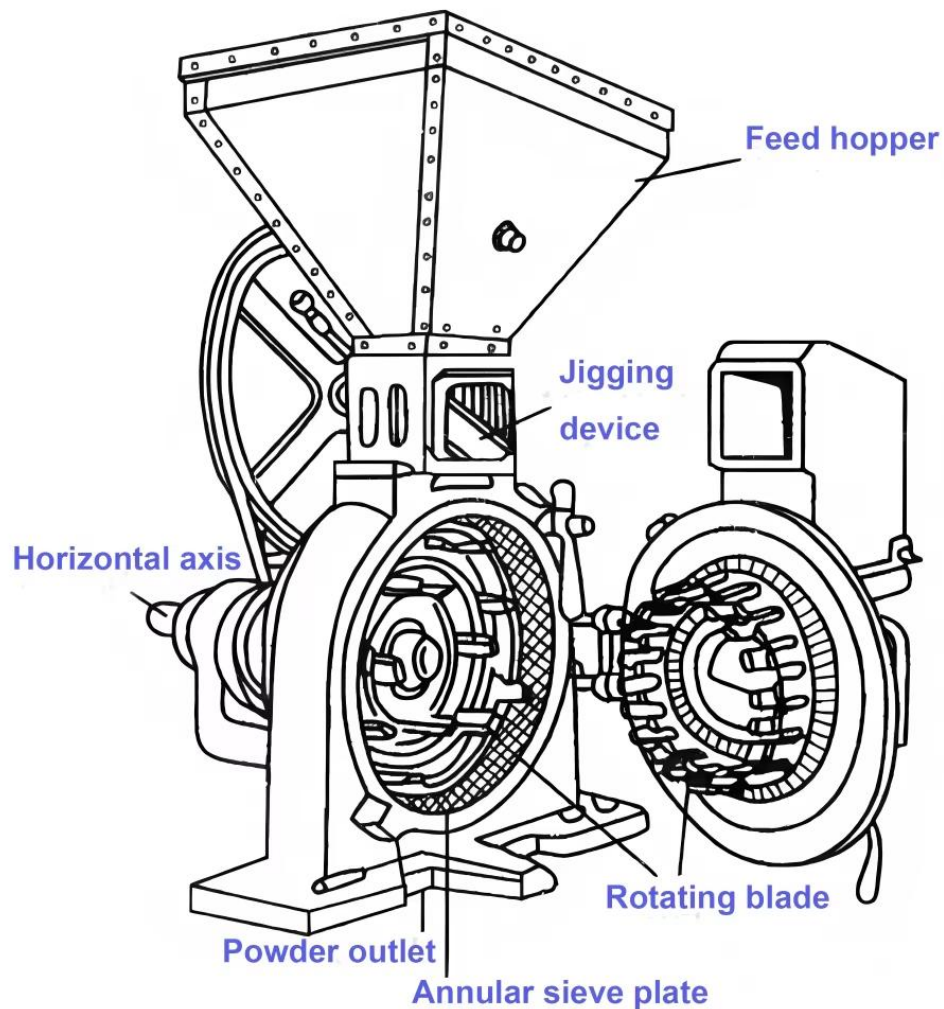

Two types hopper are available



Turbo Wheel



Hammer Mill



Chain Hammer



Air Cooling



Refiner Disc



Blade Cut





• Differences between different cavities:



Turbo Wheel



Hammer Mill



Chain Hammer



Air Cooling



Refiner Disc



Blade Cut

Turbo Wheel Type: It is especially suitable for crushing low hardness materials such as oil, viscosity, heat sensitivity, fiber, etc. It has high output, fine particle size, low noise and low energy consumption.

Hammer Mill: It is especially suitable for crushing hard materials with less fiber.

Chain Hammer: The flexible swing of the chain can effectively handle high-fiber, high-tenacity or slightly high-humidity materials to avoid entanglement.

Air cooling: The air volume in the machine cavity is large, and it is not easy to heat up. It has the advantages of stable operation, easy disassembly and cleaning, low noise, and good crushing effect.

Refiner Disc: Mainly used to make food condiments such as spices, ginger, curry powder.

Blade Cut: It has a special effect on materials containing fiber, such as herbs.





Inspection Certificate:

TISCO 山西太钢不锈钢股份有限公司
SHANXI TAI GANG STAINLESS STEEL CO., LTD.

产品质量证明书 INSPECTION CERTIFICATE

订货单位: Customer:	产品名称: 不锈钢冷轧钢带 Product: Cold rolled stainless steel coil	QR Code
收货单位: Purchaser:	交货状态: 2B 两落酸洗不切边 Condition: 2B Solid solution Pickling M	
标准 Specification Q/TB3084-2010	牌号 Grade 0Cr18Ni9DQ	合同号 MHS No. 549139-30
		证书编号 Certificate No. 6144900226149135
		客户订单 Customer Order No. 0000562493
		提单号 Consignment No. 0602614946
		车号 Train Wagon No.

序号 No.	材料号 Material No.	炉号 Heat No.	规格 Dimensions (mm)	数量 Quantity	重量 Weight(t)
1	KA601B4690E00	A1600107	2.0*1219	1	16.951
2	KA601C7170E00	A0600294	3.0*1219	1	17.550
3	KA601C7280J00	A0600295	1.2*1219	1	15.385
尺寸及外观 Acceptable Visual And Dimensions合格OK				合计 Total	3 55.886

序号 No.	分析 Max. Min.	C% S% Mn% P% S% Cr% Ni%							
		1	0.05	0.5	1.1	0.032	0.001	18.0	8.1
2	0.03	0.5	1.2	0.032	0.001	18.0	8.0		
3	0.04	0.4	1.2	0.027	0.003	18.2	8.1		

序号 No.	位置 Y.S. T.S. Rm AS HV	屈服强度 Y.S.	抗拉强度 T.S.	伸长率 EL	硬度 HV
2	2	247	691	95.5	150
3	2	243	671	90	152

注释 Notes: M=Not cutting edge; H=Heat analysis; P=Product analysis; Y.S.=Yield Strength; 常温 Room = Normal Temperature (Room Temperature); T.S.=Tensile Strength; EL=Elongation; AS=洛氏硬度(HV); 2=纵向 Transverse;

备注 Remarks: [Red stamp: 山西太钢不锈钢股份有限公司]

声明: 本产品已按上述要求制造和检验, 结果符合要求, 特此证明。
We hereby Certify That Material Described Herein Has Manufactured And Tested With Satisfactory Results In Accordance With The Requirements Of The Above Material Specification.

中国山西太原市长平路1号 邮编030003
Jiangsu, Taiyuan, Shanxi P.R. China, zip code 030003
服务热线 After-sale Service: 800-806-1998, 400-653-1998 质量负责人 Quality Manager: 刘彦 LIU YAN

日期 Date: 2023/8/3 页码 Page: 1/1



江苏德龙镍业有限公司
JIANGSU DELONG NICKEL
INDUSTRY CO., LTD.

产品质量证明书 INSPECTION CERTIFICATE



NO: DLYC231230015
Tel: 0515-86868999 转 8265
Fax: 0515-86788837
地址: 江苏省盐城市响水工业经济
Zone, Yancheng City, Jiangsu
Province

收货单位:
Purchaser: _____
牌号: SUS304
Steel Species: _____
标准:
Standard: JIS G4305:2021

合同号:
Contract No. WKCY-JS20231225B01
产品名称:
Product Name 冷轧不锈钢卷
Stainless Steel Cold Rolled Coil

发货日期:
Delivery Date 2023年12月29日
交货状态:
Delivery Condition 固溶酸洗
Solution & Anneal

序号 No.	钢卷号 Coil No.	钢种 Grade	表面状态 Surface State	边部 M/C	规格尺寸 Specification & Dimension			重量 Weight	化学成分(%) Chemical Composition (%)								力学性能 (L0=50mm) Mechanical Property			硬度 Hardness HV	钢坯号 Slab No.	建议开卷 方式
					厚度 Thickness	宽度 Width	长度 Length		C	Mn	Si	P	S	Ni	Cr	N	伸长 EL %	抗拉 T.S. Mpa	屈服 Y.S. 0.2Mpa			
41	DL13C1561B	SUS304	NO.2B	M	0.58	1250	1920	10.981	0.040	0.95	0.42	0.029	0.003	8.02	18.09	0.054	56	725	319	172	J113323103	上开
42	DL23C1746A	SUS304	NO.2B	M	1.75	1250	536	10.084	0.051	0.87	0.39	0.036	0.009	8.02	18.10	0.060	58	704	309	179	J143315505	上开
43	DL33C1188A	SUS304	NO.2B	M	2.78	1250	396	11.018	0.036	0.90	0.45	0.030	0.005	8.02	18.06	0.053	53	706	300	166	J143317201	上开
44	DL13C1480B	SUS304	NO.2B	M	1.38	1250	1024	11.029	0.036	0.87	0.48	0.032	0.006	8.02	18.03	0.053	55	710	320	171	J143318303	下开
45	DL23C1508A	SUS304	NO.2B	M	2.00	1250	540	11.034	0.037	0.88	0.42	0.031	0.007	8.01	18.03	0.054	57	707	310	169	J143312004	上开
46	DL33C1246B	SUS304	NO.2B	M	2.05	1250	545	11.064	0.037	0.93	0.49	0.033	0.005	8.03	18.05	0.054	54	700	303	166	J133336801	上开
47	DL13C1173A	SUS304	NO.2B	M	1.18	1250	944	11.091	0.040	0.92	0.38	0.031	0.004	8.01	18.02	0.049	57	726	312	165	J113322204	上开
48	DL33C1311A	SUS304	NO.2B	M	2.48	1250	488	11.095	0.055	0.90	0.48	0.030	0.008	8.01	18.01	0.053	53	695	308	170	J113325005	上开

说明: 1. 本证书不得伪造, 复印件需加盖经销商红章方有效。 This certificate shall not be forged, copy needs stamp dealer red chapter party effectively.
2. 边部 Edge: M-Mill 表示毛边, C-Cut 表示切边。
3. 本产品经检测无辐射污染, 未添加汞, non-radiative contamination, No mercury is added.
4. 本表产品已按上述要求制造和检验, 其结果符合要求, 特此证明。 We hereby certify that the product described herein has been manufactured and tested with satisfactory results in accordance with above material specification.

备注: 本公司取得资质证书
1-ISO9001:2015质量管理体系; 2-ISO45001:2018职业健康安全管理体系; 3-ISO14001:2015环境管理体系; 4-ISO10012:2003测量管理体系; 5-欧盟压力容器PED认证; 6-CPR 欧盟建筑用材料认证。
Remarks: Following quality certification is available:
1-ISO9001:2015 Quality Management System; 2-ISO45001:2018 Occupational Health and Safety Management System; 3-ISO14001:2015 Environmental Management System; 4-ISO10012:2003 measurement management system; 5-European Union pressure equipment PED certification; 6-CPR European Union certification of building materials.

质量负责人 Quality Manager: [Red stamp: 江苏德龙镍业有限公司 质量专用章]



• Require of workers operation



- 01. Women or Man both can operate it
- 02. Details operation video will provided
- 03. Provide technical guide online

Note: No need our engineer coming ! Because machines are eary to operate !!! We will help you as long as you need !





• Similar Products:



runxiangmachinery.en.alibaba.com



Spices



Grain



Pharmacy



Coffee beans

Fine grinding, suitable for medium hardness materials

Highly efficient coarse crushing, suitable for brittle materials

Hygiene priority, used in special industries.





• Similar Products:



1. Structural features: The inner cavity is equipped with **fixed claws** and **rotating claws**, and crushing is achieved through **shearing and collision between claws**.
2. Claw material: usually **high carbon steel**, alloy steel
3. Disadvantages: It is **easy to clog** high-fiber or viscous materials, and the **claws need to be replaced** regularly after wear.

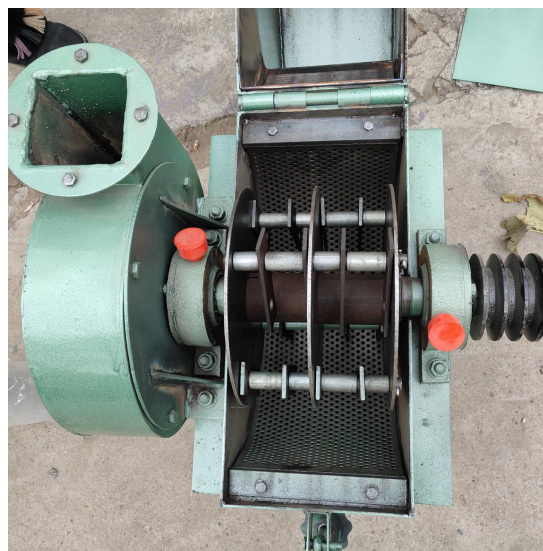

1. Structural features: The inner cavity is equipped with high-speed rotating **hammers** and **screens**, with **impact and friction** as the main crushing methods.
2. Hammer material: High manganese **steel** and alloy steel
3. Disadvantages: **Poor particle size** uniformity, high **noise**, and **easy wear** of the screen.



1. Structural features: The inner cavity is made of stainless steel, and can be equipped with claws, hammers or blades, **with various structures**.
2. Blade/claw/hammer material: usually **304 stainless steel** or 316 stainless steel
3. Disadvantages: **High cost**, suitable for industries with strict hygiene requirements.





• Related machine:



Screw Feeder



Grinder

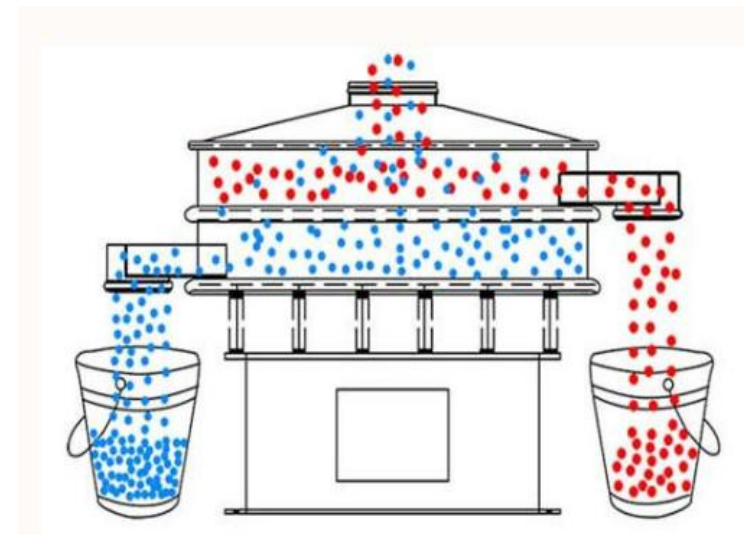

Vibrating Screen



• Workshop display:



LIVE SHOT





• Transaction Customers:

Transaction Details

All Countries / Regions

This supplier has completed 252 Transactions.

Shipping Destination	Transaction Value	Transaction Date
Austria	USD \$****	11/27/2019
Turkey	USD \$**,**	11/24/2019
Vietnam	USD \$**,**	11/22/2019
China	USD \$*,**	11/18/2019
United States	USD \$*,**	11/17/2019
China	USD \$*,**	11/15/2019
Saudi Arabia	USD \$*,**	11/12/2019
South Africa	USD \$*,**	11/12/2019

1 2 3 4 5 6 7 ... 32

Go to Page Go

High repeat purchase rate: Customers in the United States, South Africa and other regions have placed orders many times, which **confirms the reliability** and **satisfaction** of the product.

The service covers 20+ countries and regions, including the United States, China, the European Union (Austria), Southeast Asia (Vietnam, Thailand), Africa (South Africa, Ethiopia), etc., and the product has **strong adaptability**.

Shipping Destination	Transaction Value	Transaction Date
Ethiopia	USD \$*,**	10/28/2019
South Africa	USD \$**,**	10/21/2019
China	USD \$*,**	10/21/2019
China	USD \$*,**	10/21/2019
India	USD \$*,**	10/20/2019
Philippines	USD \$*,**	10/18/2019
Thailand	USD \$*,**	10/17/2019
Thailand	USD \$*,**	10/17/2019

1 2 3 4 5 6 7 ... 32

Go to Page Go



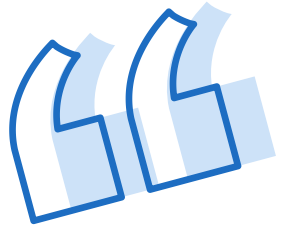

2.1. Alibaba Qualifications



Golden Supplier



SGS



Top 1 Alibaba Supplier



2.2. MADE IN CHINA Qualification





2.3. Packing Options

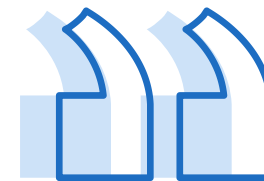

After the machine test is completed, we will wrap the machine with plastic wrap to avoid scratches



1set machine/package
Wooden Case Packing

2.4.Trade Show



Nigeria & Uzbekistan Exhibition in 2024 year
We will go to 2 countries for one year at least



2.5. Customers Visiting



Nepal Customer



Congo Customer



Ivory Coast Customer

5.Contact Information



Zhengzhou Runxiang Machinery
Equipment Co.,Ltd(sales department)

- **Contact Us**
- Zhengzhou Runxiang Machinery Equipment Co.,Ltd
- Tel: +86-371-55960109
- Mob: +86-15838007835
- E-mail: goldenmachinerysusan@gmail.com
- Address: A503, Xicheng Technology Building,
No. 41 Jinsuo Road, High-tech Zone,
Zhengzhou City, Henan province, China





**THANK YOU
FOR WATCHING**

——Zhengzhou Runxiang Machinery Equipment Co.,Ltd.

2025/7/3

